

## Sartorius Miras stainless steel industrial platform scale



## Sartorius Miras Stainless Steel Platform Scale Solution for hygienic requirement within your budget

### Practical and cost effective

The latest version Miras stainless steel industrial scale which is designed for most food applications that meets hygienic requirements but does not cost for a premium.

Miras stainless indicator can breathe via special membrane vent. It allows dry/wet air exchange. It refrains moisture air and water to go into the indicator that may lead to unnecessary damage.

It is available in two versions: AC version and AC with rechargeable battery version.

### Innovative design

The Miras platform is designed with the Finite Element Method "FEM" by using less material but without compromising on performance.

The platform is much easier to clean and has less risk of contamination due to less horizontal surface area on frame structure.

Water proof IP67 stainless steel load cell is equipped that meets stringent environment such as wet and humid condition in food factories.

### Check weighing function for quality control

Upper and lower limit can be preset in Miras indicator to check if the product is within the specific weighing range for quality control especially for pre-packaged products.

Optional relay output card can be added for installing alarm or tower light.

User can also select other applications: Simple counting function, mass unit conversion, net total formulation and toggling between gross/net values.

### Technical Features:

- Weighing range: 3 kg to 300kg
- Max readability: 15000d
- Display: 25 mm LCD, 6 digits, 7 segment with amber color backlight
- Selectable weighing unit: kg, g, Lb, oz
- Functions: Zero, Tare, Counting, Check weighing, Unit conversion, Net/Gross weight
- Indicator housing, internal frame structure and load plate: stainless steel
- Weighing system: IP67 rating stainless steel strain gauge load cell
- Auto power off function for energy saving
- Power requirement: AC 100-240V (+/- 10%) 50/60 Hz 15.5VA single phase
- DC power operation: rechargeable battery 12V, 2.3AH maintenance free lead acid battery
- Temperature range: -10 to +40°C RH85%, no condensation
- Accuracy class III
- CE Compliance



## Specifications

Model Number	Capacity (kg)	Readability (g)			Platform Size in mm	Pole height in mm
		High -L	Standard -R	Verifiable -B		
IW2S1-3DC	3	0.2	0.5	1	320 X 240	350
IW2S1-6DC	6	0.5	1	2	320 X 240	350
IW2S1-6ED	6	0.5	1	2	400 X 300	500
IW2S1-15DC	15	1	2	5	320 X 240	350
IW2S1-15ED	15	1	2	5	400 X 300	500
IW2S1-30ED	30	2	5	10	400 X 300	500
IW2S1-30FE	30	2	5	10	500 X 400	750
IW2S1-60FE	60	5	10	20	500 X 400	750
IW2S1-150FE	150	10	20	50	500 X 400	750
IW2S1-150GF	150	10	20	50	650 X 500	1000
IW2S1-150IG	150	10	20	50	800 X 600	1000
IW2S1-300GF	300	20	50	100	650 X 500	1000
IW2S1-300IG	300	20	50	100	800 X 600	1000

### Options and accessories

Relay output card (50VDC/100mA)	A5   YD001-RELAY
Rechargeable battery version	L9
RS-232 interface cable 2 m with DB9 pins for PC or printer connection	A33   YD001I-232-9
RS-232 interface cable 2 m with DB25 pins for other device	A34   YD001I-232-25
Indicator holder for bench top fixing (only for AC version)	YDH12CWS
Indicator stainless steel wall holder (only for AC version)	YDH 02CIS
Stripe data printer	YDP-20-OCE

### Model selection Guide:

IW2S1-150FE-L-L9  
Capacity: 150 kg with 500x400 mm platform

L=15000d, 10 g readability  
L9=rechargeable battery version



Rechargeable Battery Version



A.C. Version

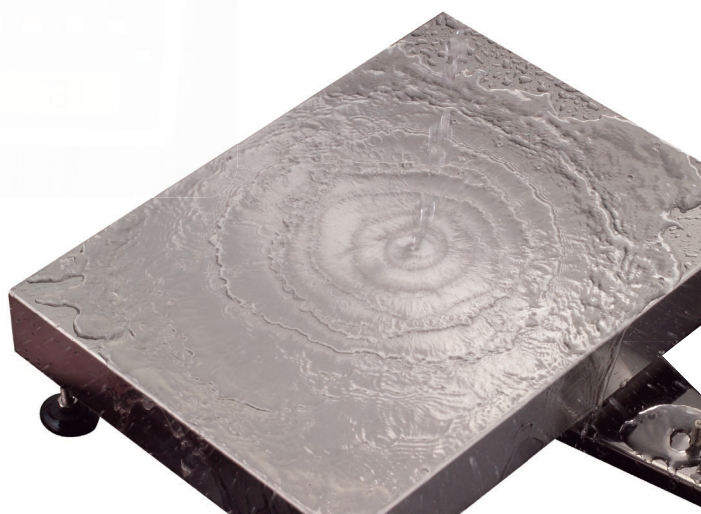

## Dimensions

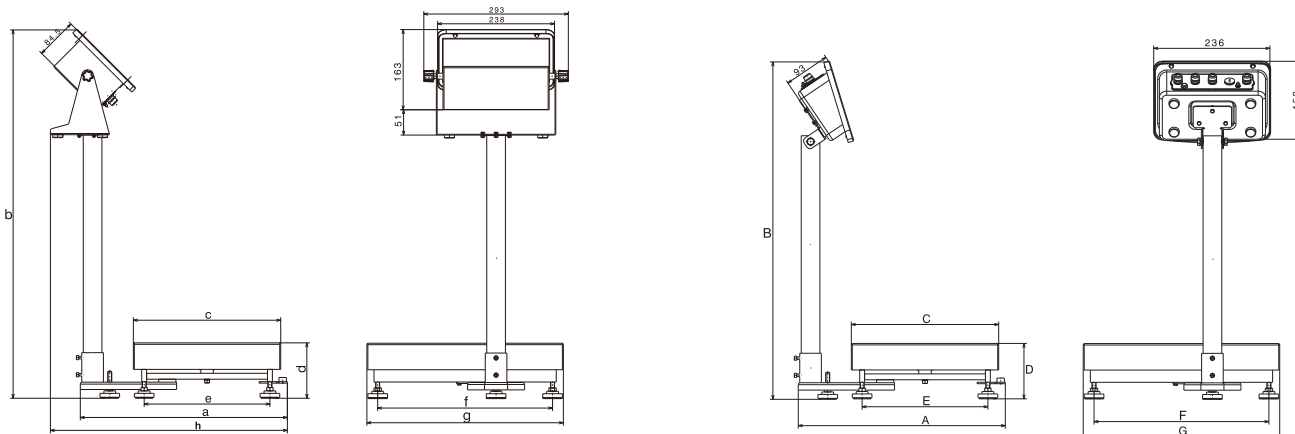

### Rechargeable Battery Version

Design/ Dimension	a	b	c	d	e	f	g	h
DC	360	600	240	105	195	275	320	410
ED	420	750	300	112	256	356	400	482
FE	520	1000	400	130	355	455	500	570
GF	-	-	500	153	453	603	650	-
IG	-	-	600	153	552	752	800	-

### A.C. version

Design/ Dimension	A	B	C	D	E	F	G
DC	360	540	240	105	195	275	320
ED	420	690	300	112	256	356	400
FE	520	940	400	130	355	455	500
GF	-	-	500	153	453	603	650
IG	-	-	600	153	552	752	800

## Asia / Pacific

### Regional headquarter

Sartorius Mechatronics Hong Kong Ltd.  
Unit 1110-12, Lu Plaza  
2 Wing Yip Street  
Kwun Tong, Kowloon, Hong Kong  
Phone: +852.2774.2678  
Fax: +852.2766.3526

### Japan

Sartorius Mechatronics Japan K.K.  
4th Floor, da Vinci Shinagawa II  
1-8-11 Kita-Shinagawa, Shinagawa-ku  
Tokyo 140-0001  
Phone: +81.3.3740.5407  
Fax: +81.3.3740.5406

### South Korea

Sartorius Mechatronics Korea Ltd.  
4th Floor, Yangjae B/D 209-3  
Yangjae-Dong, Seocho-Ku  
137-893 Seoul, South Korea  
Phone: +82.2.575.6945  
Fax: +82.2.575.6949

### China

Sartorius Scientific Instruments (Beijing) Co. Ltd.  
No. 33 Yu An Road  
Tianzhu Airport Industry Zone, Zone B  
Shun Yi District, 101300 Beijing, China  
Phone: +86.10.8042.6300  
Fax: +86.10.8042.6486

### Malaysia

Sartorius Stedim Malaysia Sdn. Bhd.  
Lot L3-E-3B, Enterprise 4  
Technology Park Malaysia  
Bukit Jalil, 57000 Kuala Lumpur  
Phone: +60.3.8996.0622  
Fax: +60.3.8996.0755

### Thailand

Sartorius Mechatronics (Thailand) Co. Ltd  
No. 129 Rama 9 Rd  
Huaykwang  
Bangkok 10310  
Phone: +66.2643.8361  
Fax: +66.2643.8367

### India

Sartorius Mechatronics India Pvt. Ltd.  
10, 6th Main, 3rd Phase Peenya  
KIADB Industrial Area  
Bangalore - 560058  
Phone: +91.80.2837.7728  
Fax: +91.80.4117.1840

### Philippines

Sartorius Mechatronics Philippines, Incorporated  
Unit 2403, 88 Corporate Center  
141 Valero corner Sedeno Streets  
Makati City, Philippines 1227  
Phone: +63.2.750.0492  
Fax: +63.2.750.0490

### Australia

Sartorius Stedim Australia Pty. Ltd.  
Unit 17/104 Ferntree Gully Road  
Waverley Business Park  
East Oakleigh, Victoria 3166  
Phone: +61.3.9590.8800  
Fax: +61.3.9590.8828

### Indonesia

PT. Sartorius Mechatronics Indonesia  
Wisma Metropolitan 1, L-11 Kav. 29  
Jl. Jenderal Sudirman  
Jakarta 12920, Indonesia  
Phone: +62.21.5790.7129  
Fax: +62.21.5790.7132

### Singapore

Sartorius Mechatronics Singapore Pte. Ltd.  
10 Science Park Road  
#02-25 the Alpha, Singapore Science Park II  
Singapore 117684  
Phone: +65.6872.3966  
Fax: +65.6778.2494

Sartorius AG  
Weender Landstrasse 94-108  
37075 Goettingen, Germany

Specifications subject to change without notice.

Publication No.: WI-1517-e08121  
Order No.: 98649-009-19

Phone+49.551.308.0  
Fax +49.551.308.3289

www.sartorius-mechatronics.com